

# S3219E

## ELECTRIC SLAB SCISSOR LIFTS



- Self-propelled electric scissor lift
- Compact & nimble
- Drives through a standard doorway
- Suitable for indoor and outdoor use
- Easy to use & maintain

 **snorkel**  
[www.snorkellifts.com](http://www.snorkellifts.com)

# ELECTRIC SLAB SCISSOR LIFTS

# S3219E

## DIMENSIONS S3219E

Max. working height	7.79m
Max. platform height (A)	5.79m
Platform size (stowed)	1.61m x 0.71m
Platform size (extended)	2.53m x 0.71m
Deck extension length	0.91m
Overall length (C)	1.79m
Overall width (D)	0.81m
Stowed height (B)	2.09m
Min. height (guardrails folded)	1.65m
Ground clearance (stowed)	66mm
Ground clearance (elevated)	19mm

## PERFORMANCE

Platform capacity (SWL)	250kg
Max. drive height	5.79m
Max. wind speed	12.5m/s
Max. drive speed (stowed)	3.2km/h
Max. drive speed (elevated)	0.6km/k
Gradeability	25%
Inside turning radius	0.1m
Outside turning radius	1.63m
Tires	non-marking solid rubber
Controls	proportional
Drive system	2 wheel drive

## POWER

Power source	4 x 6V 220amp hour batteries
Charger	90 - 240V, 25amp

## WEIGHT

Weight	1,564kg
--------	---------

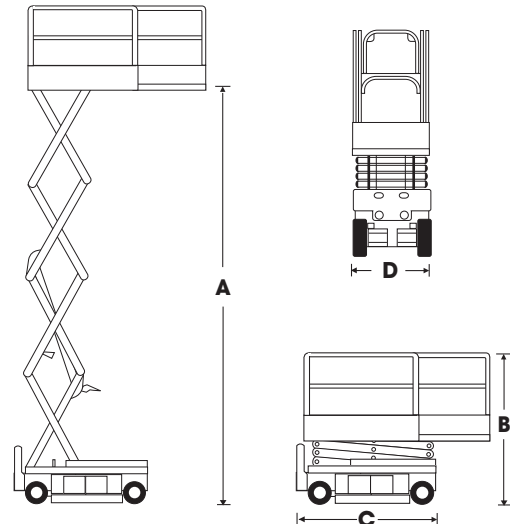

## STANDARD FEATURES

- Roll-out deck extension with locking handles
- Non-marking tyres
- Swing-out service trays
- Saloon door entry
- Key switch
- 2 persons + equipment capacity indoors
- 1 person + equipment capacity outdoors
- Proportional controls
- Power line to platform
- Hour meter & onboard diagnostics display
- Dual lanyard attachments points
- Flashing amber light
- CE approved

## OPTIONS

- Special paint colours
- Environmental (green) oil

## TURNING RADIUS

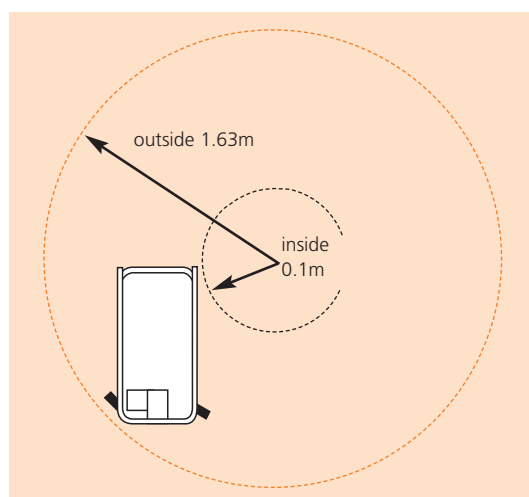

**snorkel** [www.snorkellifts.com](http://www.snorkellifts.com)

Vigo Centre, Birtley Road,  
Washington, Tyne & Wear,  
NE38 9DA, U.K.

t: +44 (0) 845 1550 057  
e: sales@snorkellifts.com