

S1930E/1932E

SLAB SCISSOR LIFTS



- Self-propelled electric micro scissor lifts
- Compact and nimble
- Drives through a standard doorway
- 0.81m wide model rated for outdoor use
- Easy to use and maintain

 **snorkel**
www.snorkellifts.com

SLAB SCISSOR LIFTS

S1930E/1932E

DIMENSIONS	S1930E	S1932E
Max. working height	7.6m	7.6m
Max. platform height (A)	5.6m	5.6m
Platform size (stowed)	0.64m x 1.56m	0.64 x 1.56m
Platform size (extended)	0.64m x 2.44m	0.64 x 2.44m
Deck extension length	0.88m	0.88m
Overall width (D)	0.76m	0.81m
Overall length (C)	1.85m	1.85m
Stowed height (B)	2.17m	2.17m
Min. height (guardrails folded)	1.90m	1.90m
Wheelbase	1.37m	1.37m
Ground clearance (stowed)	63mm	63mm
Ground clearance (elevated)	19mm	19mm

PERFORMANCE	S1930E	S1932E
Platform capacity (SWL)	227kg	227kg
Max. operating wind speed (1 person on platform)	12.5m/s	12.5m/s
Max. drive height	5.6m	5.6m
Max. drive speed (stowed)	3.2km/h	3.2km/h
Max. drive speed (elevated)	0.6km/h	0.6km/h
Raise/lower time	20/26 seconds	20/26 seconds
Gradeability	25%	25%
Inside turning radius	0.13m	0.13m
Outside turning radius	1.64m	1.64m
Tyres	305mm x 102mm non-marking solid rubber	
Controls	proportional	proportional
Drive system	2 wheel drive	2 wheel drive

POWER	S1930E	S1932E
Power source	4 x 6V 220 amp hour batteries	
Charger	90 - 240V, 25 amp	

WEIGHT	S1930E	S1932E
Gross weight	1,600kg	1,570kg

TURNING RADIUS

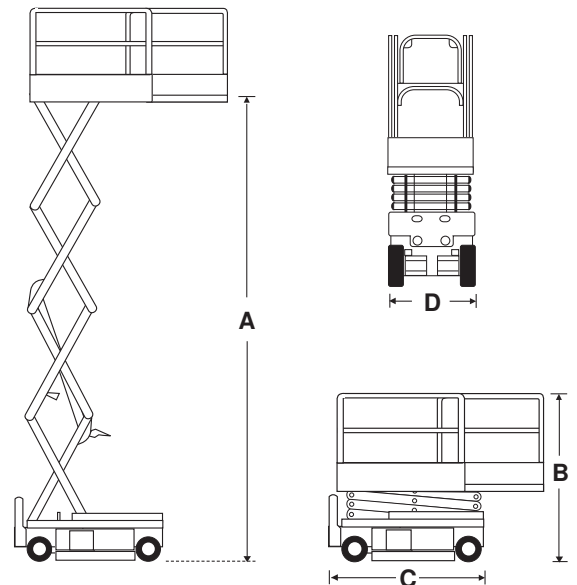
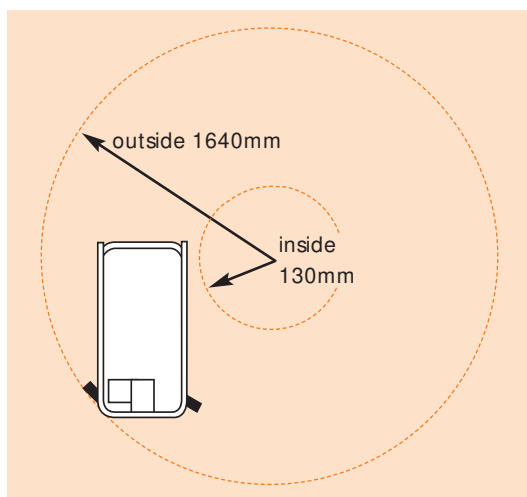

STANDARD FEATURES

- Pothole protection system
- Non-marking tyres
- Proportional controls
- 0.8m extension deck
- Power line to platform (no sockets)
- Approved for outdoor use with one person on platform (S1932E only)
- Swing-out service trays
- Horn
- Hour meter
- Level sensor with drive/lift interlock
- CE approved

OPTIONS

- Special paint colours
- Flashing amber beacon
- Dual lanyard anchorage point

snorkel www.snorkellifts.com

36 Bruce Road, Levin,
5510, New Zealand
t: +64 (0)6 368 9168
f: +64 (0)6 368 9164
e: sales.nz@snorkellifts.com